

Model - 55

Three-roller
bending machine

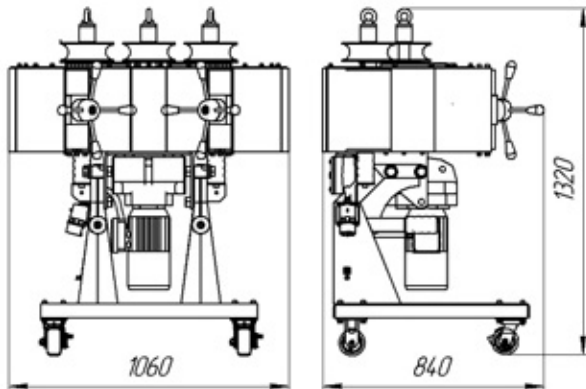

Oriented

Making of rings, arcs, spirals with specified coils step lifting of by 3-roller cold bending of tubes:



and profiles

Abilities

- Synchronized continual 3 rollers drive
- Control of theoretical bending radius
- Spiral step lifting control
- Work in vertical and horizontal position



Tooling

Complete set of tooling for 3-roller bending consists of 3 rollers



Steel or caprolon rollers for tubes of different materials and covering

Technical data

	Model 55	Model 55 Y (reinforced)
Maximum tube diameter, mm	60	80
CLR, min.		300
CLR, max		Not limited
Tubes movement speed, m/min		5
Quantity of driving rollers		3
Quantity of tube grip mechanisms		2
Quantity of spiral step lifting mechanisms		Up to 2
Power	1,1 kWt	1,5 kWt
Frequency/voltage		50 Гц, 380В
LxHxB, mm		1060x1320x840
Weight, kg	480	520

Base set

- Bending machine with remote control panel
- Packing
- Training to Customer's personnel
- Operation manual

Advanced options

- Mounting of speed control system
- Mounting of spiral step lifting mechanisms
- Delivery of optional tooling



Baltic Machine-building Company

Tel./Fax: +7 812 3310840, +7 812 3313970; Tel.: +7 812 7167377 E-mail: Bmc@trubogib.spb.ru Web-site: Http://www.trubogib.spb.ru