

# JUNIOR 3R-E-30

Three-roller bending machine

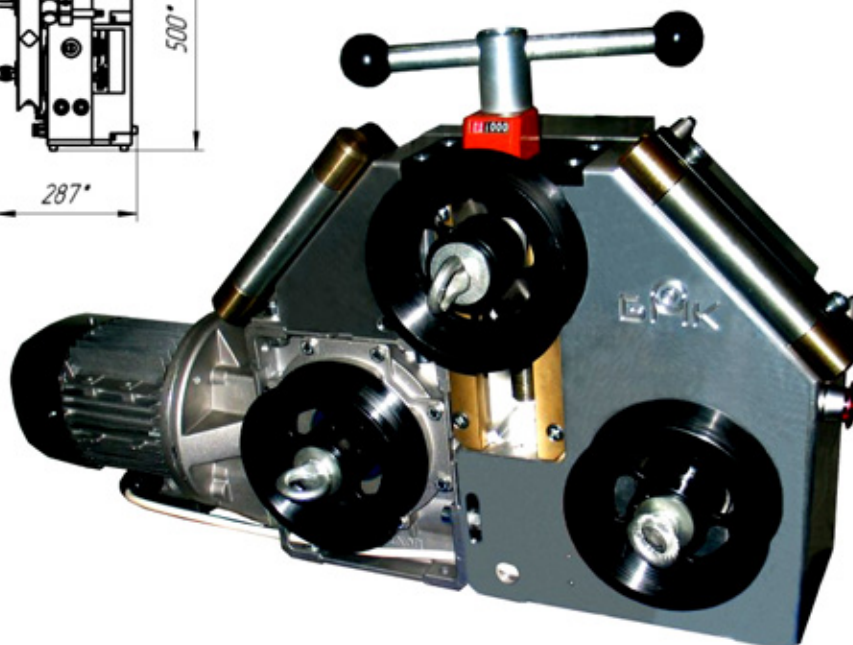
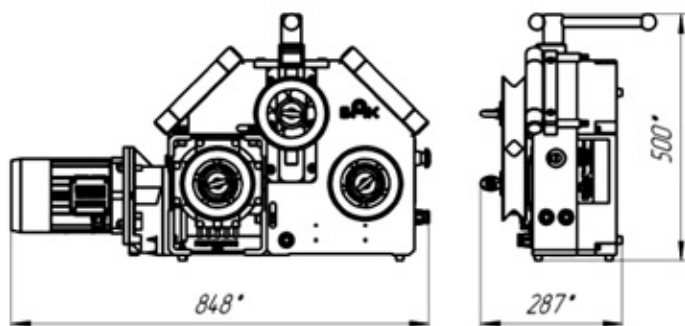

## Oriented:

- Making of rings, arcs, spirals with specified coils step lifting of tubes



and profiles



by 3-roller bending method

## Abilities

- Control of theoretical bending radius
- Spiral step lifting control
- Works in vertical and horizontal position
- Digitizer of roller tightening

## Tooling

Complete set of tooling for 3-roller bending consist of 3 rollers

Steel rollers for tubes of different materials and coverings



## Technical data

Maximum tube diameter, mm	30
CLR, min	90
CLR, max	Not limited
Tubes movement speed, m/min	3
Quantity of driving rollers	2
Quantity of spiral step lifting mechanisms	2
Power/frequency/voltage	0,75 kWt / 50 Hz / 380 V
LxHxB, mm	848x500x287
Weight, kg	70

## Base set

- Bending machine
- Set of 3 universal rollers
- Two spiral step lifting devices
- Operation manual
- Packing
- Training to Customer's personnel

## Advanced options

- Delivery of optional tooling



Baltic Machine-building Company

Tel./fax: +7 812 3310840, +7 812 3313970, tel.: +7 812 7167377; e-mail: [bmc@trubogib.spb.ru](mailto:bmc@trubogib.spb.ru); web-site: <http://www.tubend.ru>